

STM32VLDISCOVERY LCD Interface Expansion Board (EB-STM32DISCOVERY-LCD) User Guide

1 EB-STM32DISCOVERY-LCD Overview

The EB-STM32DISCOVERY-LCD is an extension board for the STM32VLDISCOVERY Development Board.

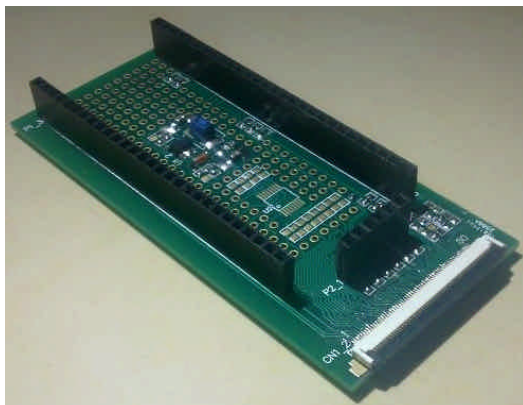

Figure 1. LCD connector expansion board for STM32VLDISCOVERY

The expansion board has built in LED backlight driver circuit and 60pin FPC connector for the Kentec LCDs (3.5 inch: K350QVG-V2-F; 4.3 inch: K430WQC-V3-FF; 5.0 inch: K50DWN2-V1-FF; 7.0 inch: K70DWN2-V1-FF; 9.0 inch: K90DWN2-V1-FF).

2 EB-STM32DISCOVERY-LCD Dimensions

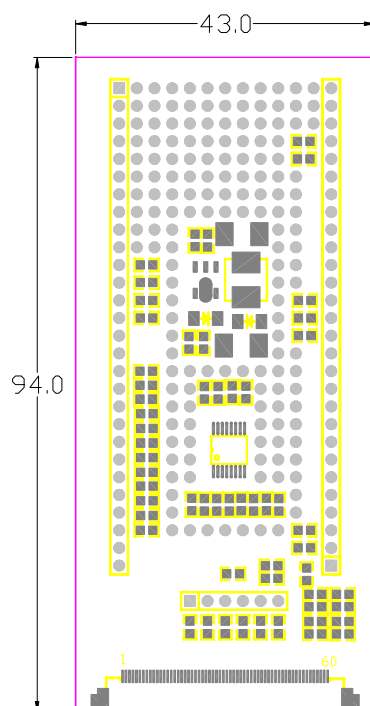

Figure 2. Outline Dimensions

3 EB-STM32DISCOVERY-LCD Interface

Table 1-1. Main Interface Signal P1 (28pin header connect to STM32VLDISCOVERY MCU board)

Pin	STM32VLDISCOVERY PIN Symbol	EB-STM32DISCOVERY-LCD Symbol	Description
1	GND	GND	Ground (0V)
2	NC	NC	No connection
3	3V3	3V3	Power supply (+3.3V)
4	VBAT	NC	No connection
5	PC13	NC	No connection
6	PC14	NC	No connection
7	PC15	NC	No connection
8	PD0	NC	No connection
9	PD1	NC	No connection
10	RST	NC	No connection
11	PC0	D0	LCD parallel data bus bit 0
12	PC1	D1	LCD parallel data bus bit 1
13	PC2	D2	LCD parallel data bus bit 2
14	PC3	D3	LCD parallel data bus bit 3
15	PA0	NC	No connection
16	PA1	NC	No connection
17	PA2	NC	No connection
18	PA3	NC	No connection
19	PA4	NC	No connection
20	PA5	SCL	LCD serial clock input
21	PA6	NC	No connection
22	PA7	SDA	LCD serial data input
23	PC4	D4	LCD parallel data bus bit 4
24	PC5	D5	LCD parallel data bus bit 5
25	PB0	RD	LCD parallel data read control signal
26	PB1	WR	LCD parallel data write control signal
27	PB2	NC	No connection
28	GND	GND	Ground (0V)

Table 1-2. Main Interface Signal P2 (6pin header connect to STM32DISCOVERY MCU board)

Pin	STM32DISCOVERY PIN Symbol	EB-STM32DISCOVERY-LCD Symbol	Description
1	PB10	D10	LCD parallel data bus bit 10
2	PB11	D11	LCD parallel data bus bit 11
3	PB12	D12	LCD parallel data bus bit 12
4	PB13	D13	LCD parallel data bus bit 13
5	PB14	D14	LCD parallel data bus bit 14
6	PB15	D15	LCD parallel data bus bit 15

Table 1-3. Main Interface Signal P3 (28pin header connect to STM32DISCOVERY MCU board)

Pin	STM32DISCOVERY PIN Symbol	EB-STM32DISCOVERY-LCD Symbol	Description
1	GND	GND	Ground (0V)
2	PC6	D6	LCD parallel data bus bit 6
3	PC7	D7	LCD parallel data bus bit 7
4	PC8	NC	No connection
5	PC9	NC	No connection
6	PA8	NC	No connection, (optional for LCD backlight control by R37)
7	PA9	NC	No connection
8	PA10	NC	No connection
9	PA11	NC	No connection
10	PA12	NC	No connection
11	PA13	NC	No connection
12	PA14	NC	No connection
13	PA15	NC	No connection
14	PC10	RS	LCD command/data select signal
15	PC11	CS	LCD chip select signal
16	PC12	Reset	LCD reset signal
17	PD2	NC	No connection
18	PB3	NC	No connection
19	PB4	NC	No connection
20	PB5	NC	No connection
21	PB6	NC	No connection
22	PB7	NC	No connection
23	Boot	NC	No connection
24	PB8	D8	LCD parallel data bus bit 8
25	PB9	D9	LCD parallel data bus bit 9
26	5V	5V	Power supply for LCD backlight circuit (+5V)
27	NC	NC	No connection
28	GND	GND	Ground (0V)

Table 2. LCD Interface Signal (CN1 60pin ZIF connector to LCD module)

Pin	Symbol	Description
1, 2	LED_K	LED power supply (-)
3, 4	LED_A	LED power supply (+)
5	GND	Ground (0V)
6	XR	4-wire resistor touch screen terminal
7	YD	
8	XL	
9	YU	
10	GND	Ground (0V)

Continued Table 2, LCD Interface Signal (60pin ZIF connector to LCD module)

11~13	NC	No Connection
14	Reset	Reset input signal for LCD
15	CS	Chip select for LCD
16~19	NC	No Connection
20	D0	Data bit 0, default connected to GND on MCU board
21~25	D1~D5	Data bit 1 ~ bit 5
26, 27	NC	No Connection
28~30	D6~D8	Data bit 6 ~ bit 8
31	D9	Data bit 9, default connected to GND on MCU board
32, 33	D10, D11	Data bit 10 ~ bit 11
34, 35	NC	No Connection
36~41	D12~D17	Data bit 12 ~ bit 17
42~44	GND	Ground (0V)
45, 46	AVDD	Power supply (3.3V)
47, 48	VCC	Power supply (3.3V)
49	RS	Command/Data select signal for LCD
50	RD	Read control signal for LCD
51	WR	Write control signal for LCD
52	PS0	LCD interface select pin for K350QVG-V2-F, default set to i8080 16-bit parallel.
53	PS1	
54	PS2	
55	PS3	
56, 57	NC	No connection
58~60	GND	Ground (0V)

4 Schematics

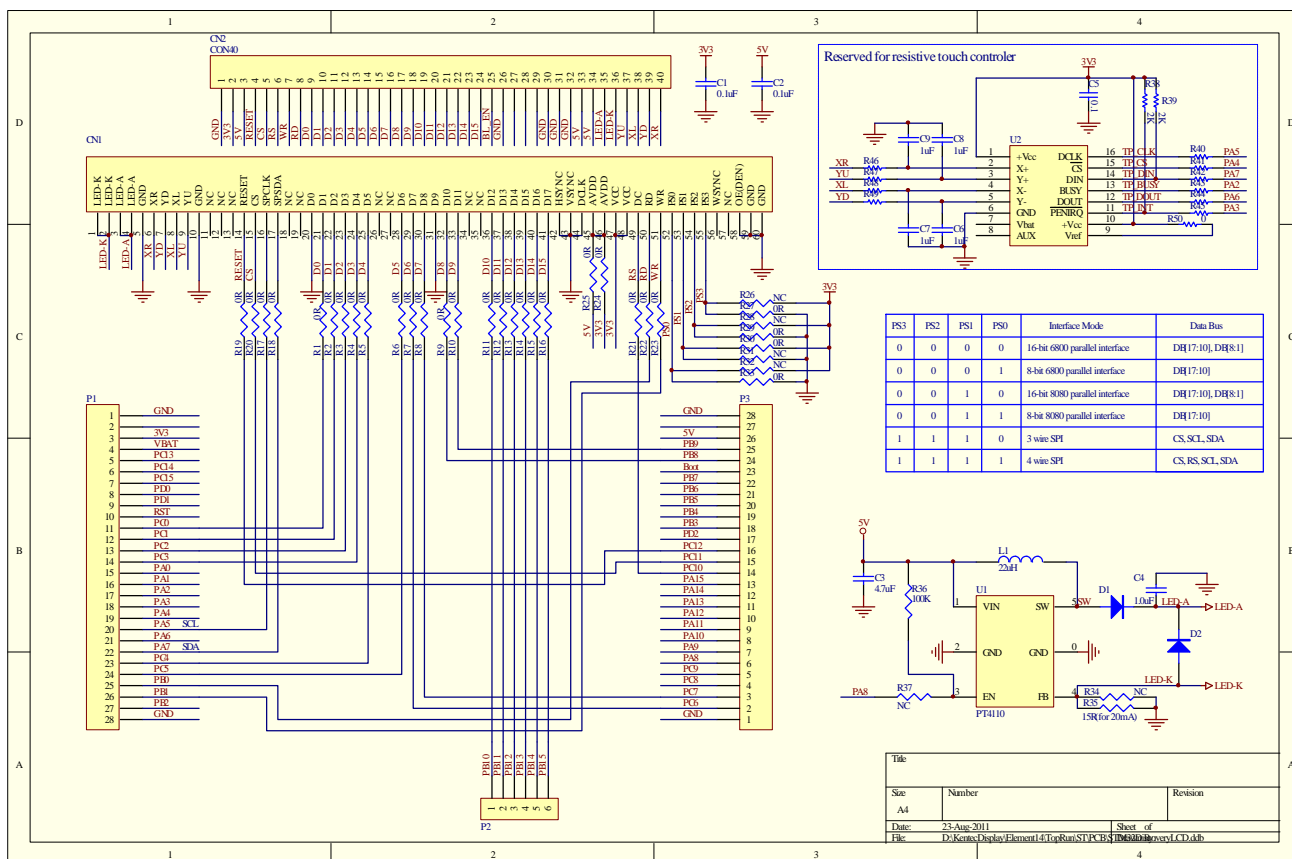

Figure 3. Expansion board schematic

4 Components Location

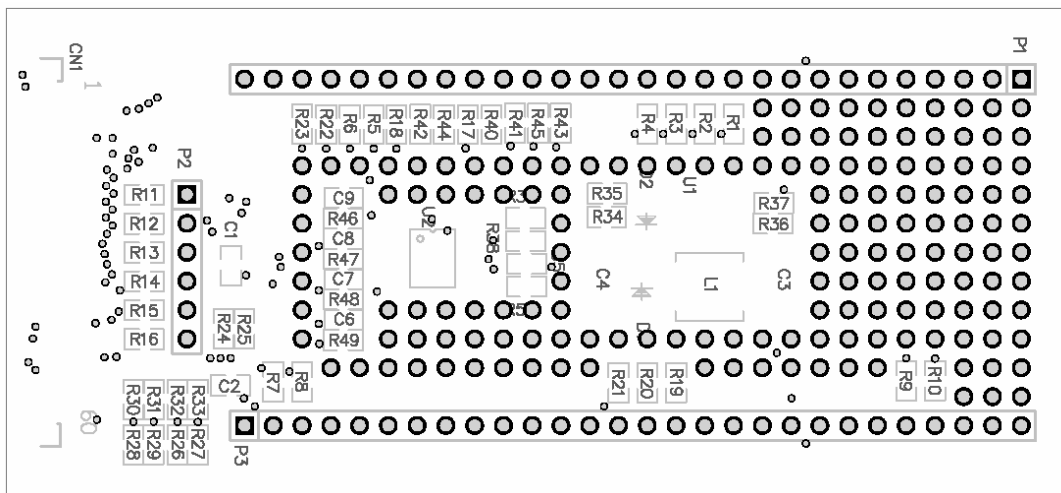

Figure 4. Expansion board components layout

5 LCD driver code examples

Bellow attachment is the source code for the K350QVG-V2-F.

NO.	Document	Attachment
1	Source code package	