



K70DWN0-V1-F

Product

7 inch Diagonal
800 x 480 x RGB Dots
16.7M colors TFT display
With white LED backlight
With 4-wire resistive touch screen



CONTENTS

	<u>Page No.</u>
1. DOCUMENT REVISION HISTORY	3
2. GENERAL DESCRIPTION	4
3. MECHANICAL SPECIFICATIONS	5
4. INTERFACE SIGNALS	6
5. ABSOLUTE MAXIMUM RATINGS	7
6. ELECTRICAL SPECIFICATIONS	7
7. OPTICAL CHARACTERISTICS	8
8. TIMING CHARACTERISTICS	10
9. RELIABILITY TEST ITEM	13
10. SUGGESTIONS FOR USING LCD MODULES	14



1. Document revision history :

DOCUMENT REVISION	DATE	DESCRIPTION	PREPARED BY	APPROVED BY
01	2010.09.07	First Draft	MF	
02	2010.09.28	Modified input signal timing	XH Dai	



2. General Description

NO.	Item	Unit	Specification	Remark
1	Screen Size	inch	7(Diagonal)	
2	Display Resolution	Dot	800RGB(W)x480(H)	
3	Overall Dimension	mm	164.9(W)x100(H)x7.3 (D)	Note 1
4	Active Area	mm	154.08(W)x85.92(H)	
5	Pixel Pitch	mm	0.1926(W)x0.179(H)	
6	Color Configuration	-	Tri-Gate	
7	Color Depth	-	16.7M Color	Note 2
8	NTSC Ratio	%	50	
9	Display Mode	-	Normally White	
10	Panel Surface Treatment	-	Anti-Glare, 3H	
11	Weight	g	TBD	
12	Panel Power Consumption	mW	TBD	
13	Backlight Power Consumption	W	1.56	
14	Viewing Direction		6 o'clock(Gray inversion)	

Note 1: Not include controller board and FPC.

Note 2: Full color display depends on 24-bit data signal.



3. Mechanical Specifications

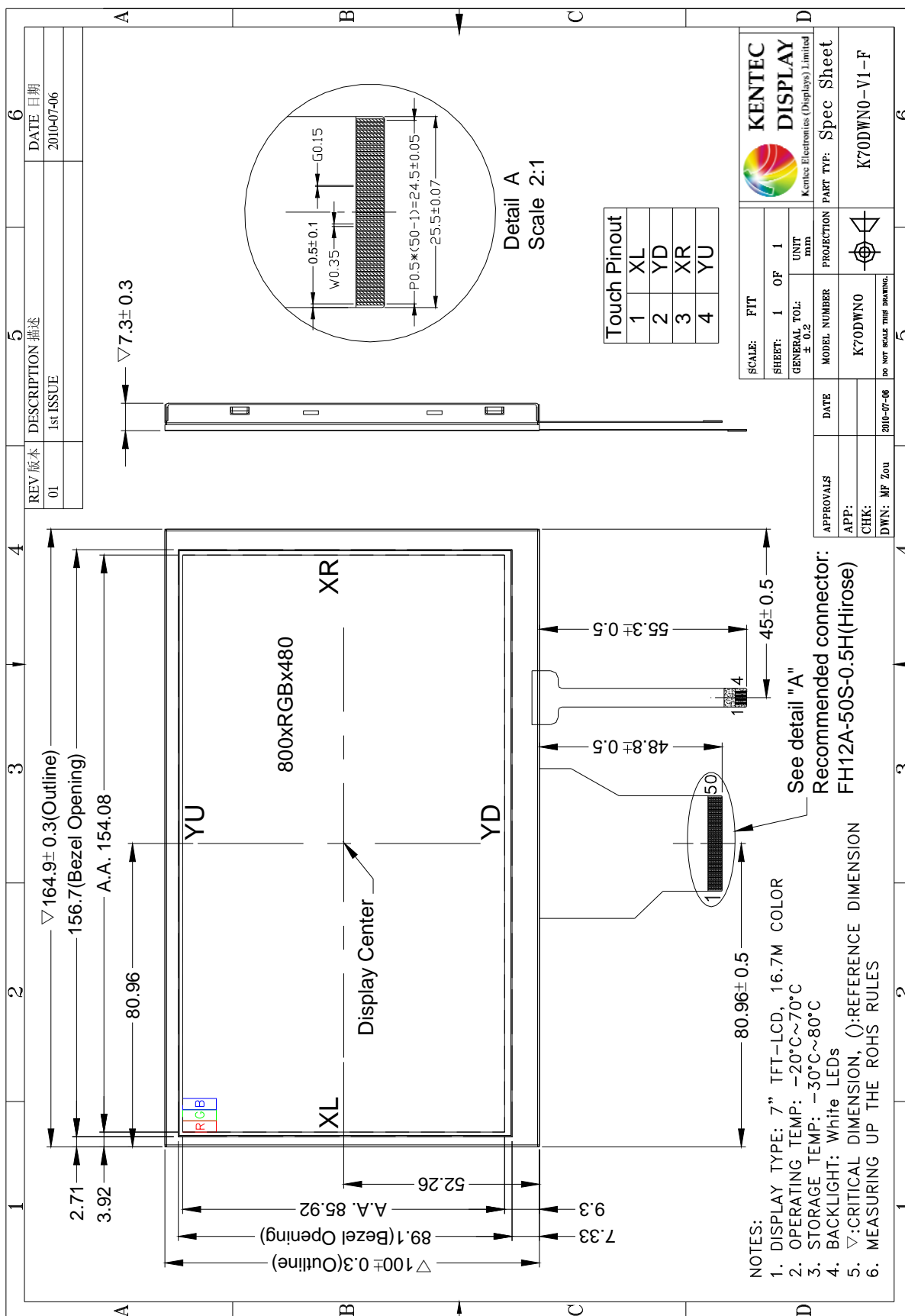

Figure 1: Outline Drawing



4. Interface signals

Pin No.	Symbol	I/O	Description
1	VLED+	P	Power for LED backlight (Anode)
2	VLED+	P	Power for LED backlight (Anode)
3	VLED-	P	Power for LED backlight (Cathode)
4	VLED-	P	Power for LED backlight (Cathode)
5	GND	P	Ground
6	VCOM	I	Common electrode driving voltage
7	DVDD	P	Power for digital circuit
8	MODE	I	DE/SYNC mode selection
9	DE	I	Data enable input (High active)
10	VS	I	Vertical Sync input
11	HS	I	Horizontal Sync input
12	DB7	I	Blue data input (MSB)
13	DB6	I	Blue data input
14	DB5	I	Blue data input
15	DB4	I	Blue data input
16	DB3	I	Blue data input
17	DB2	I	Blue data input
18	DB1	I	Blue data input
19	DB0	I	Blue data input (LSB)
20	DG7	I	Green data input (MSB)
21	DG6	I	Green data input
22	DG5	I	Green data input
23	DG4	I	Green data input
24	DG3	I	Green data input
25	DG2	I	Green data input
26	DG1	I	Green data input
27	DG0	I	Green data input (LSB)
28	DR7	I	Red data input (MSB)
29	DR6	I	Red data input
30	DR5	I	Red data input
31	DR4	I	Red data input
32	DR3	I	Red data input
33	DR2	I	Red data input
34	DR1	I	Red data input
35	DR0	I	Red data input
36	GND	P	Ground
37	DCLK	I	Data clock input
38	GND	P	Ground
39	L/R	I	Left/Right scan direction selection
40	U/D	I	Up/Down scan direction selection
41	VGH	P	Positive power supply voltage for Gate driver
42	VGL	P	Negative power supply voltage for Gate driver
43	AVDD	P	Power for analog circuit
44	RESET	I	H/W global reset
45	NC	-	No connection
46	VCOM	I	Common electrode driving voltage
47	DITHB	I	Dithering enable
48	GND	P	Ground
49	NC	-	No connection
50	NC	-	No connection

Note: Connector Type : 50Pin 0.5mm pitch. Recommended Connector : FH12A-50S-0.5H(Hirose)



5. Absolute Maximum Ratings

Table 3: Electrical Maximum Ratings

Parameter	Symbol	Condition	Min.	Max.	Unit	Note
Power voltage	DVDD	GND=0V	-0.5	5.0	V	
	AVDD	GND=0V	6.5	13.5	V	
	VGH	GND=0V	-0.3	40	V	
	VGL	GND=0V	-20	0.3	V	
	VGH-VGL	-	-	40	V	
Input signal voltage	Vi	GND=0V	-0.3	DVDD+0.3	V	
	VCOM	GND=0V	TBD	TBD	V	
Operation temperature	Topa		-20	70	°C	
Storage temperature	Tstg		-30	80	°C	

6. Electrical Specifications

Typical Electrical Characteristics

At Ta = 25 °C, DVCC= 3.3V, GND=0V.

Table 5

Parameter	Symbol	Min.	Typ.	Max.	Unit	Remark	
Power supply	DVDD	3	3.3	3.6	V		
	AVDD	(10.2)	(10.4)	(10.6)	V		
	VGH	(15.3)	(16.0)	(16.7)	V		
	VGL	(-7.7)	(-7.0)	(-6.3)	V		
Input signal voltage	VCOM	Vcom	(3.6)	(3.8)	(4.0)	V	
	H level	Vih	0.7DVDD		DVDD	V	
	L level	Vil	0		0.3DVDD	V	
Supply current (Logic & LCD)	ICC	TBD	TBD	TBD	mA		
Supply voltage of LED backlight	VLED	(9.3)	(9.9)	(10.5)	V		
Supply current of LED backlight	ILED	-	(80)	(120)	mA	Note 1	
Power consumption	P	-	1.26	-	W		

Note 1: LED backlight is LED lightbar type(18pcs of LED).

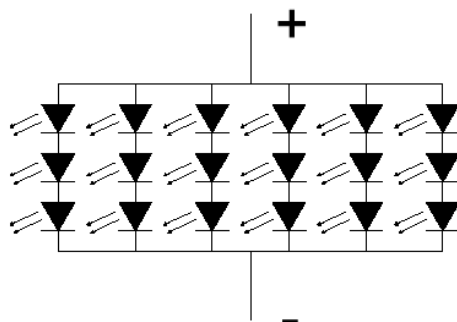



7. Optical Characteristics

Table 6: Optical specifications

Items	Symbol	Condition	Specifications			Unit	Note
			Min.	Typ.	Max.		
Luminance	L _w		200	250	-	cd/m ²	
Contrast Ratio	CR		400	500	-	-	
Response Time	T _R +T _F		-	25	50	ms	
Chromaticity	White	X _w	(0.26)	(0.31)	(0.36)	-	
		Y _w	(0.28)	(0.33)	(0.38)	-	
Viewing angle	Hor.	φ1 + φ2	120	140	-	deg.	
	Ver.	θ1 + θ2	100	120	-		

Note 1: Definition of Contrast Ratio (CR):

The contrast ratio can be calculated by the following expression.

$$\text{Contrast Ratio (CR)} = L_{63} / L_0$$

L63: Luminance of gray level 63

L0: Luminance of gray level 0

$$\text{CR} = \text{CR}(10)$$

CR (X) is corresponding to the Contrast Ratio of the point X at Figure in Note 5.

Note 2: Definition of Response Time (TR, TF):

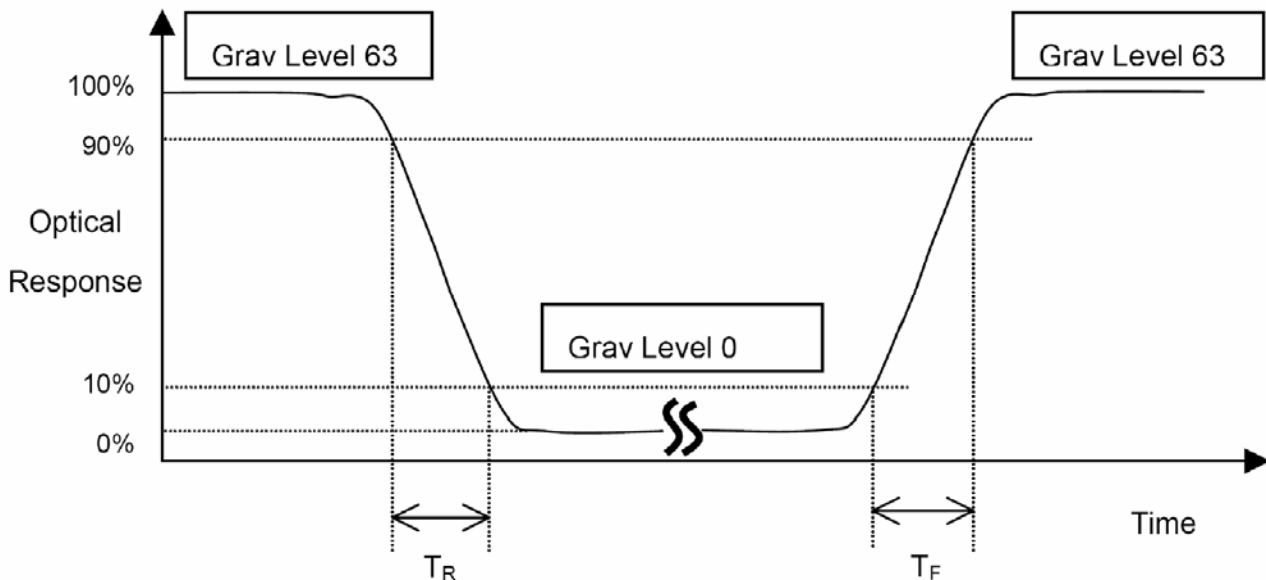

Figure 3



Note 3: Viewing Angle

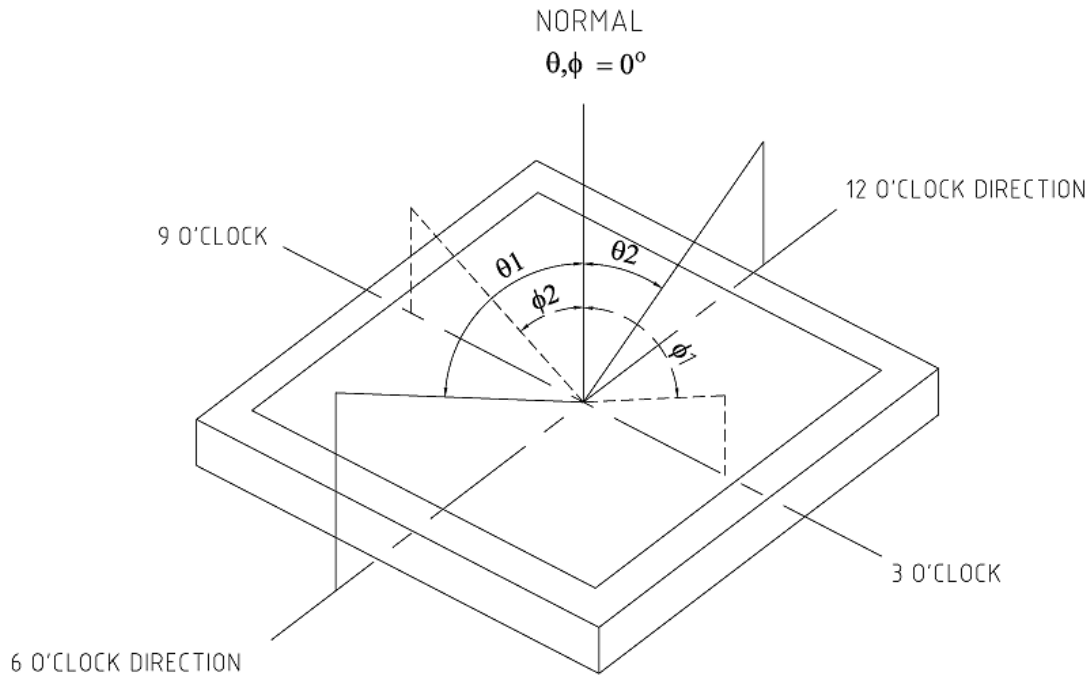

Figure 4

The above “Viewing Angle” is the measuring position with Largest Contrast Ratio; not for good image quality. View Direction for good image quality is 6 O’clock. Module maker can increase the “Viewing Angle” by applying Wide View Film.

Note 4: Measurement Set-Up:

The LCD module should be stabilized at a given temperature for 20 minutes to avoid abrupt temperature change during measuring. In order to stabilize the luminance, the measurement should be executed after lighting Backlight for 20 minutes in a windless room.

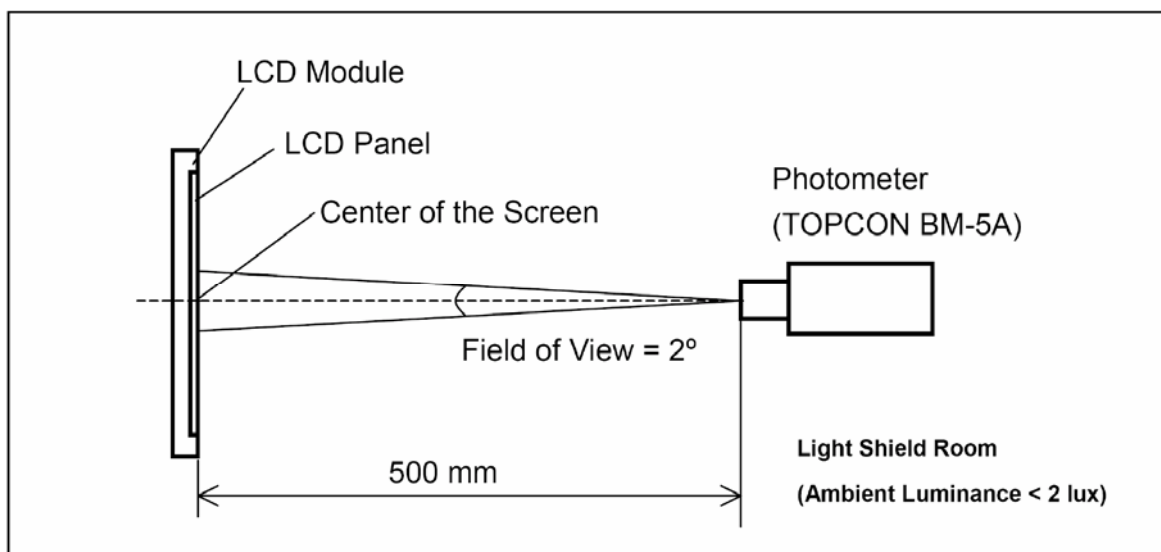

Figure 5



8. AC Characteristics

8.1 Power on/off sequence

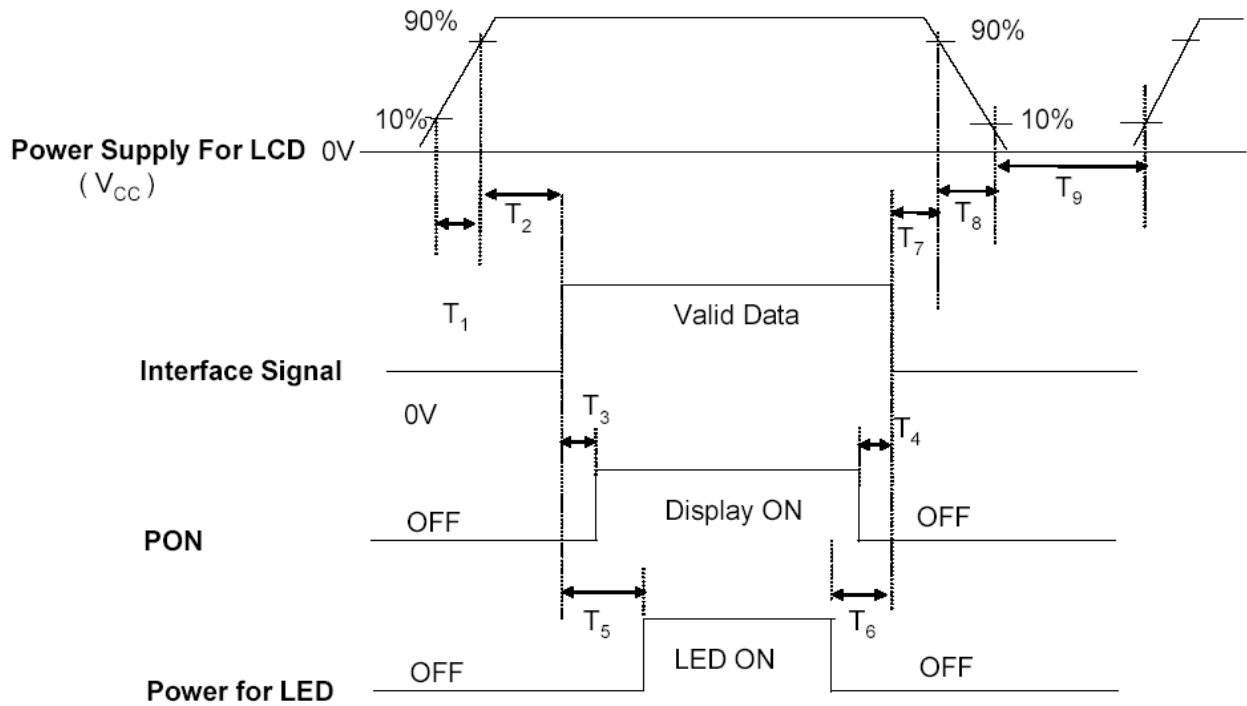

Table 6: Power on/off sequence table

Parameter	Value			Units
	Min.	Typ.	Max.	
T ₁	0.5	-	10	(ms)
T ₂	0	-	50	(ms)
T ₃	20	-	-	(ms)
T ₄	20	-	-	(ms)
T ₅	200	-	-	(ms)
T ₆	200	-	-	(ms)
T ₇	0	-	50	(ms)
T ₈	0	-	10	(ms)
T ₉	400	-	-	(ms)



8.2 Signal timing (VDD=3.3V)

8.2.1 Signal input timing

Item	Symbol	Value			Unit	Remark
		Min.	Typ.	Max.		
HS setup time	Thst	8	-	-	ns	
HS hold time	Thhd	8	-	-	ns	
VS setup time	Tvst	8	-	-	ns	
VS hold time	Tvhd	8	-	-	ns	
Data setup time	Tdsu	8	-	-	ns	
Data hold time	Tdhd	8	-	-	ns	
DE steup time	Tesu	8	-	-	ns	
DE hold time	Tehd	8	-	-	ns	
DVdd power on slew rate	Tpor	-	-	20	ms	From 0 to 90% DVdd
RESET pulse width	Trst	1	-	-	ms	
DCLK cycle time	Tcoh	20	-	-	ns	
DCLK pulse duty	Tcwh	40	50	60	%	

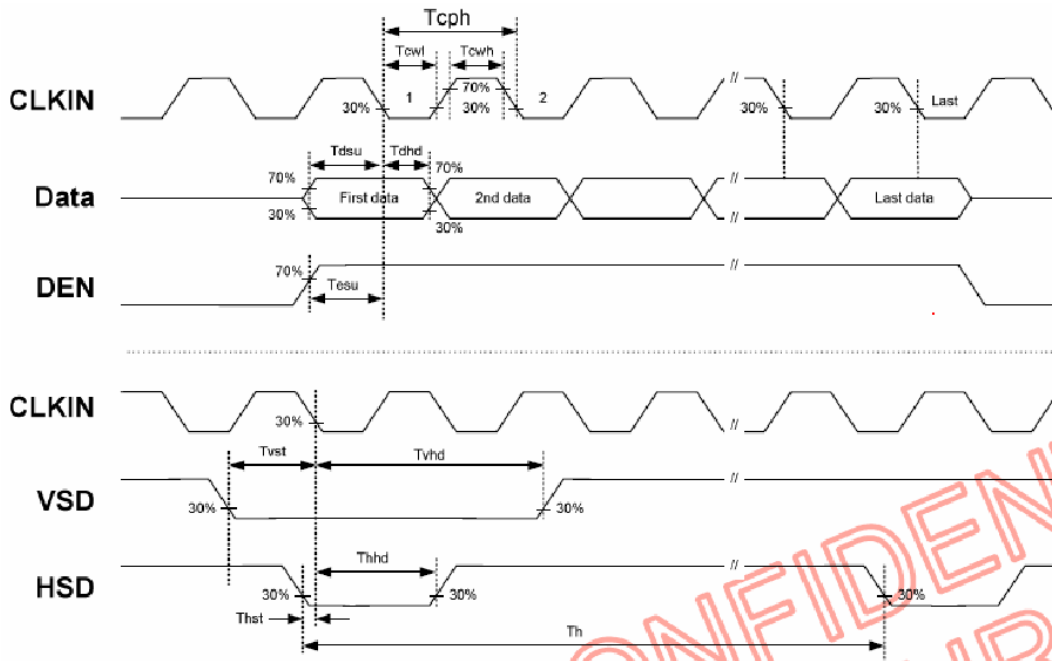

8.2.2 Signal input timing

Item	Symbol	Value			Unit	Remark
		Min.	Typ.	Max.		
Horizontal display area	thd	-	800	-	DCLK	
DCLK frequency	fclk	26.4	33.3	46.8	MHz	
One horizontal line	th	862	1056	1200	DCLK	
HS pulse width	thpw	1	-	40	DCLK	
HS blanking	thb	46	46	46	DCLK	
HS front porch	thfp	16	210	354	DCLK	

Item	Symbol	Value			Unit	Remark
		Min.	Typ.	Max.		
Vertical display area	tvd	-	48	-	TH	
VS period time	tv	510	525	650	TH	
VS pulse width	tvpw	1	-	20	TH	
VS blanking	tvb	23	23	23	TH	
VS front porch	tvfp	7	22	147	TH	

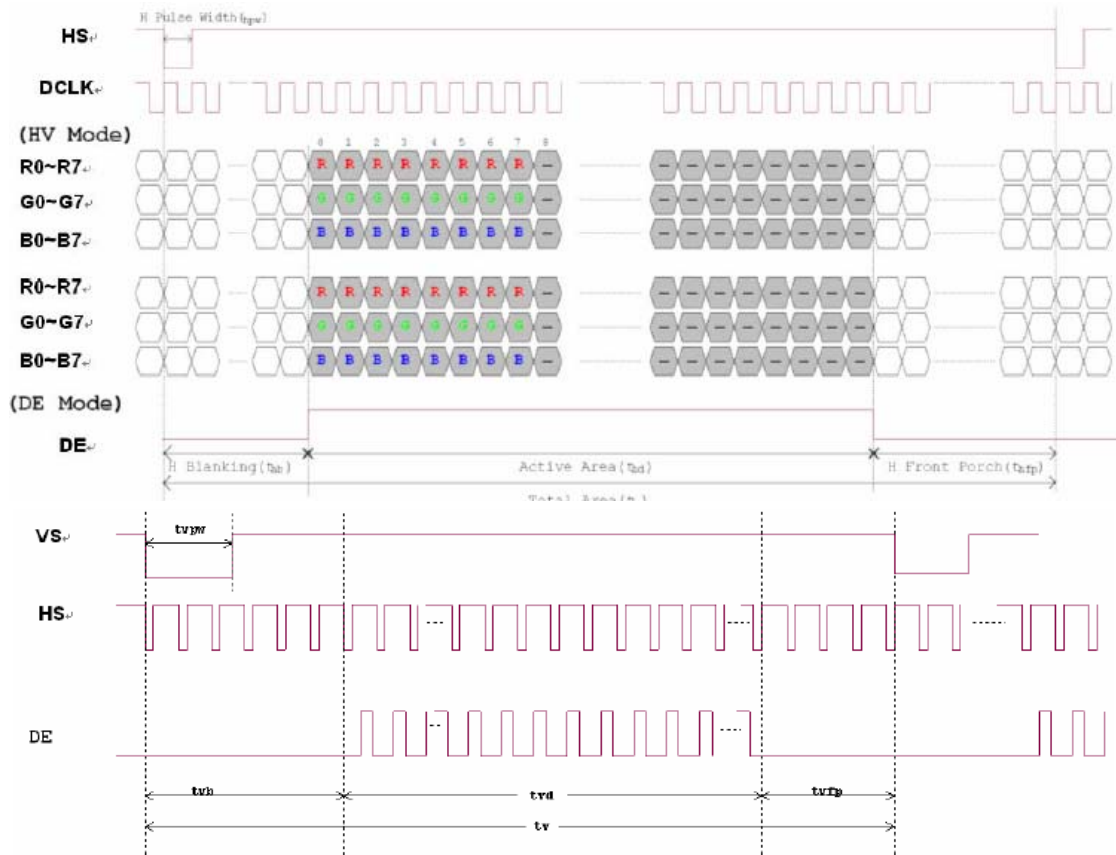

- Horizontal Timing

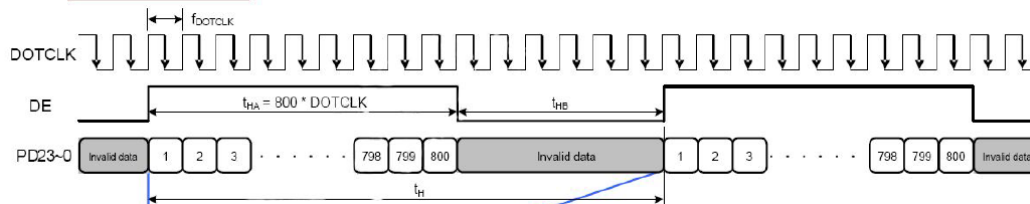

- Vertical Timing

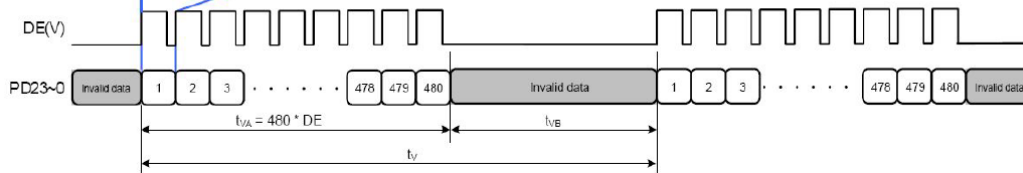

Table 6: Signal timing



9. Reliability Test Item

	Test Item	Test Condition	Remark
1	High temperature storage	70°C; 240H	
2	Low temperature storage	-20°C; 240H	
3	High temperature High humidity	50°C, 80%RH; 240H	Operation
4	High temperature operation	60°C; 240H	
5	Low temperature operation	-10°C; 240H	
6	Temperature Shock	-20°C→60°C; 100cycle, 1Hrs/cycle	Non-operation
7	Electrostatic Discharge	Contact ±4kV, Class B Air ±8kV, Class B	
8	Image sticking	25°C, 4H	
9	Vibration	Frequency range : 10~55Hz Stoke : 1.5mm Sweep : 10~55~10Hz 2 Hours for each direction of X,Y,Z (total 6 Hours)	Non-operation JIS C7021, A-10 Conduction A : 15 minutes
10	Mechanical shock	100G, 6ms, ±X, ±Y, ±Z, 3 times for each direction	Non-operation JIS C7021, A-10 Conduction C
11	Vibration (with carton)	Random vibration : 0.015G ² /Hz from 2~200Hz -6dB/Octave from 200~500Hz	ICE 68-34
12	Drop (with carton)	Height : 60cm 1 corner, 3 edges, 6 surfaces	
13	Pressure	5 kg, 5 sec	



10. Suggestions for using LCD modules

10.1 Handling of LCM

1. The LCD screen is made of glass. Don't give excessive external shock, or drop from a high place.
2. If the LCD screen is damaged and the liquid crystal leaks out, do not lick and swallow. When the liquid is attach to your hand, skin, cloth etc, wash it off by using soap and water thoroughly and immediately.
3. Don't apply excessive force on the surface of the LCM.
4. If the surface is contaminated ,clean it with soft cloth. If the LCM is severely contaminated , use Isopropyl alcohol/Ethyl alcohol to clean. Other solvents may damage the polarizer . The following solvents is especially prohibited: water , ketone Aromatic solvents etc.
5. Exercise care to minimize corrosion of the electrode. Corrosion of the electrodes is accelerated by water droplets, moisture condensation or a current flow in a high-humidity environment.
6. Install the LCD Module by using the mounting holes. When mounting the LCD module make sure it is free of twisting, warping and distortion. In particular, do not forcibly pull or bend the I/O cable or the backlight cable.
7. Don't disassemble the LCM.
8. To prevent destruction of the elements by static electricity, be careful to maintain an optimum work environment.
 - Be sure to ground the body when handling the LCD modules.
 - Tools required for assembling, such as soldering irons, must be properly grounded.
 - To reduce the amount of static electricity generated, do not conduct assembling and other work under dry conditions.
 - The LCD module is coated with a film to protect the display surface. Exercise care when peeling off this protective film since static electricity may be generated.
9. Do not alter, modify or change the the shape of the tab on the metal frame.
10. Do not make extra holes on the printed circuit board, modify its shape or change the positions of components to be attached.



11. Do not damage or modify the pattern writing on the printed circuit board.
12. Absolutely do not modify the zebra rubber strip (conductive rubber) or heat seal connector
13. Except for soldering the interface, do not make any alterations or modifications with a soldering iron.
14. Do not drop, bend or twist LCM.

10.2 Storage

1. Store in an ambient temperature of 5 to 45 °C, and in a relative humidity of 40% to 60%. Don't expose to sunlight or fluorescent light.
2. Storage in a clean environment, free from dust, active gas, and solvent.
3. Store in antistatic container.

- END -